

# Measuring Video Feedthrough in Pulsed Signals

MG3690A Signal Generators

## Introduction

Video feedthrough is a very misunderstood term, which is used in the specification of pulse performance for microwave synthesizers. There are several ways of specifying it. Depending on the application, one way may provide more information than another. This note is an attempt to explain what video feedthrough is, how it can be measured, and what effect it can have on devices being tested.

As far as electronics is concerned, the term video was originally used to describe the “picture” signal, which modulated a RF carrier for television in the 1920’s. When this signal was detected and applied to a scanning CRT, a picture was produced. During World War II, video was the term applied to the detected RF pulse received by the radar, as the pulse could be seen on the radar CRT. At that time, oscillographs (oscilloscopes) could not display RF signals. A crystal detector was used to rectify the RF and produce an envelope of the RF signal, which could be displayed by the oscillograph. So, video is also the term applied to the detected RF from a crystal detector. The term video is also used to describe the signal, which modulates a RF carrier.

The term video feedthrough also comes from the early days of radar during World War II. Some of the modulating signals for the RF carrier would “feed through” the circuitry into the detected RF path, and give a false display on the CRT; hence, the term video feedthrough.



## Ideal Drive Pulse

Video feedthrough as used with microwave synthesizers or any RF source, which is pulse modulated, describes how much of the drive signal for the modulator, usually a PIN diode modulator, “feeds through” to the RF output. This video feedthrough can cause distortion of the RF pulse when it is detected and in some cases can damage a device under test.

Figure 1 shows an ideal video drive pulse, the resulting RF pulse, and the detected RF from a negative polarity crystal detector.

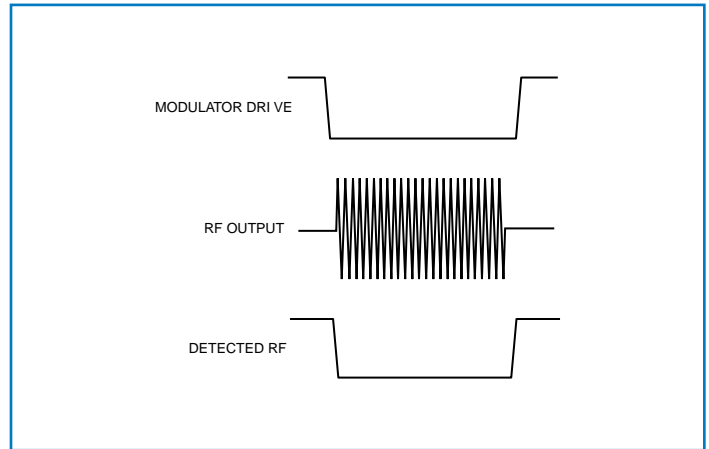

Figure 1. I/O characteristics for ideal video drive pulse

## Inherent Feedthrough from the Source

Figure 2 shows a more typical waveform obtained by many non-Anritsu synthesizers today. There is a slight overshoot on the leading edge and a slight roll-off on the trailing edge. This can be observed by connecting a synthesizer RF output directly to the 50Ω input of an oscilloscope, such as a TEK 2465, and setting the RF output for a 100 MHz pulsed output.

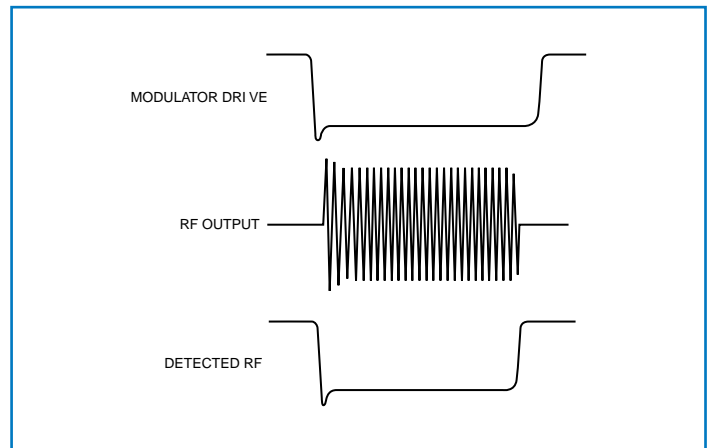

Figure 2. I/O characteristics for non-ideal video drive pulse

## Video Feedthrough from Differentiated Signal

Even with no noticeable overshoot on the voltage waveform of the modulated driver there can still be video feedthrough as shown in Figure 3. The video feed-through here is caused by the differentiated modulator drive signal. The signal is differentiated by the DC blocking capacitors in the control modulator, which is discussed later. Notice that the RF output signal is a summation of the video feedthrough and the RF itself. The detected RF signal shows the effect of the video feed through. On the leading edge, the video feedthrough exaggerates the overshoot, and on the trailing edge, there is a positive signal caused by the video pulse discharging the filter capacitance of the detector diode.

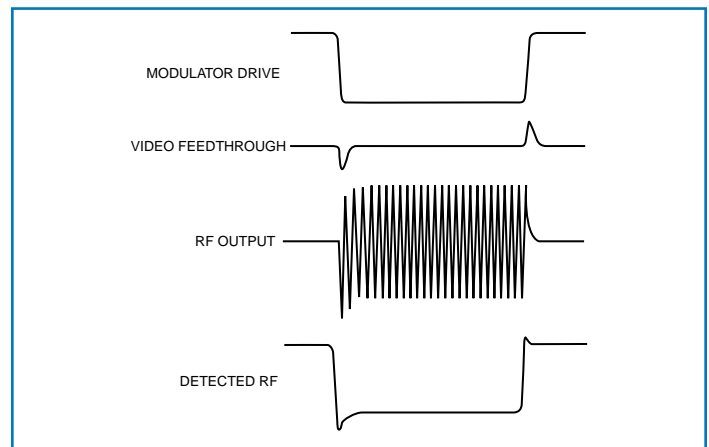

Figure 3. Video feedthrough caused by differentiated modulator current drive signal

## Video Feedthrough from Inverted Modulator Signal

Figure 4 also shows the pulse signal with video feedthrough. However, the modulator drive signal is inverted, as would be the case when the PIN diodes were reversed. Notice the video pulses are also inverted. The effect on the RF output, however, is quite different than in Figure 3. The video feedthrough degrades the rise-time as seen by a crystal detector, and the trailing edge has an overshoot, which is not on the RF waveform.

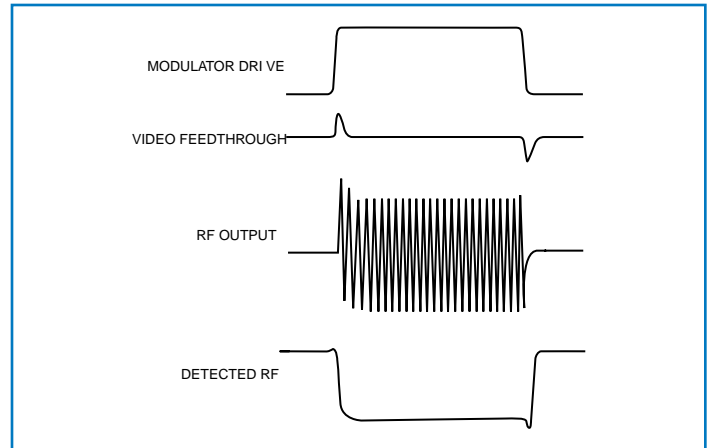

Figure 4. Video feedthrough when the modulator signal is inverted

## Video Feedthrough from PIN Modulator

Figure 5 shows how a typical PIN modulator generates video feedthrough. A PIN diode is a current device; that is, it has high resistance with no current and low resistance when current is applied through it. A typical PIN diode draws about 20 mA of current for its minimum resistance. For its maximum resistance, it is usually reversed-biased a few volts to reduce its capacitance and thereby reduce its insertion loss. A synthesizer without compensation to reduce video feedthrough would look like Figure 5.

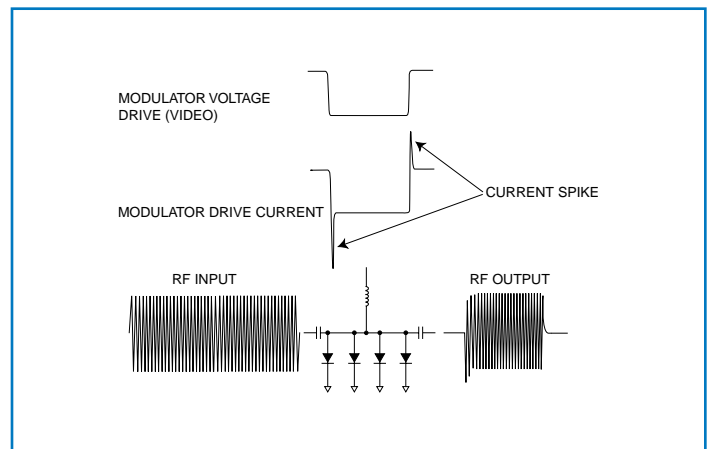

Figure 5. The effect of PIN diode on the modulator signal

Figure 6 shows a simplified schematic of a PIN diode pulse modulator, which minimizes video feedthrough. This is accomplished by adding a low value inductor, on the order of a few nanohenries, from the RF output line to ground. This provides a short-circuit to the high frequency components of the video feedthrough while providing a high impedance path to the RF. As can be seen on the RF output signal, the video feedthrough is not noticeable, especially when using a crystal detector.

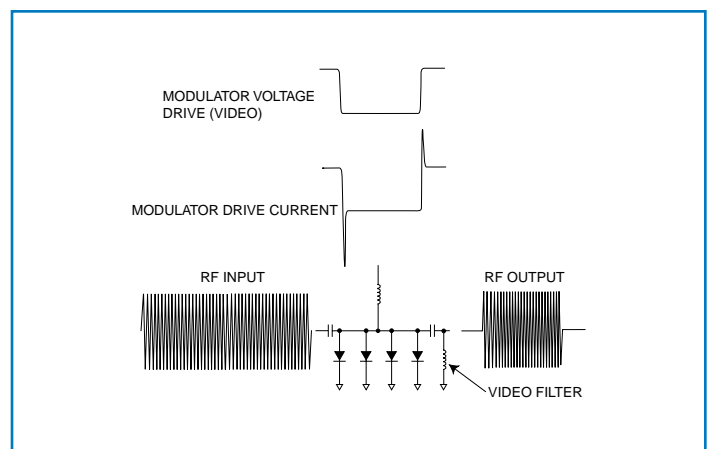

Figure 6. Small inductor minimizes video feedthrough in a PIN modulator circuit

## Control Modulator

The Anritsu MG3690A synthesizer uses a “control modulator” for amplitude modulation and level control of each oscillator. A simplified schematic of the control modulator is shown in Figure 7.

The first three diodes are used for level control by the ALC circuit. The second four diodes are the pulse modulator. Notice there is a video filter between the level control diodes and the pulse modulator diodes in addition to a video filter on the output of the pulse modulator diodes. The level control diodes are 400 ns diodes, while the pulse diodes are 10 ns diodes. The video filter between the two sets of diodes prevents the video feedthrough from modulating the level control diodes. The video filter on the output of the pulse diodes (actually located in the RF output multiplexing switch) prevents the video feedthrough from showing up at the RF output and also prevents the video feedthrough from modulating the PIN diodes in the multiplexing switch.

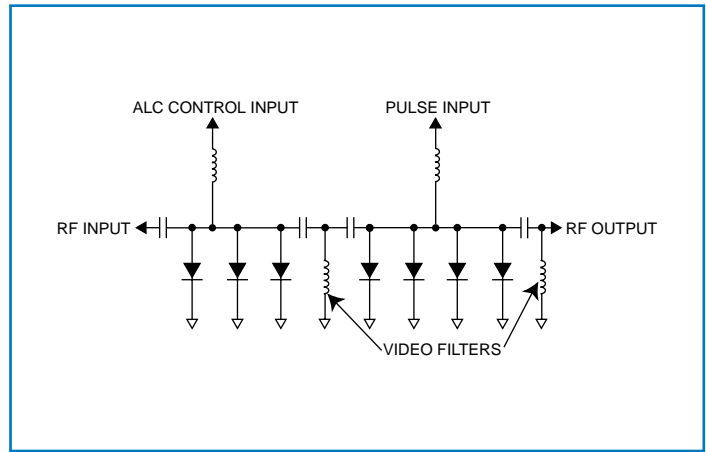

Figure 7. The schematic of a “control modulator”

## Frequency Analysis of Video Feedthrough

The above discussion examined the RF directly with an oscilloscope or at the RF detected by a crystal detector with the resulting video observed on an oscilloscope. What if we look at the RF output on a spectrum analyzer? Figure 8 shows a 5 GHz RF frequency modulated with a 100 kHz square wave. The analyzer is set of 1 MHz/div sweep width and a 10 kHz resolution bandwidth. Notice that all of the even harmonics of the modulating signal are suppressed. This verifies the definition of a square-wave, which is, the fundamental frequency plus all of its odd harmonics. The spacing of the combines is 100 kHz, which matches the 10  $\mu$ s pulse period of the modulating signal. The modulated RF carrier level will be approximately 10 dB below the CW level. This loss of power in the carrier is because it is in the sidebands of the signal.

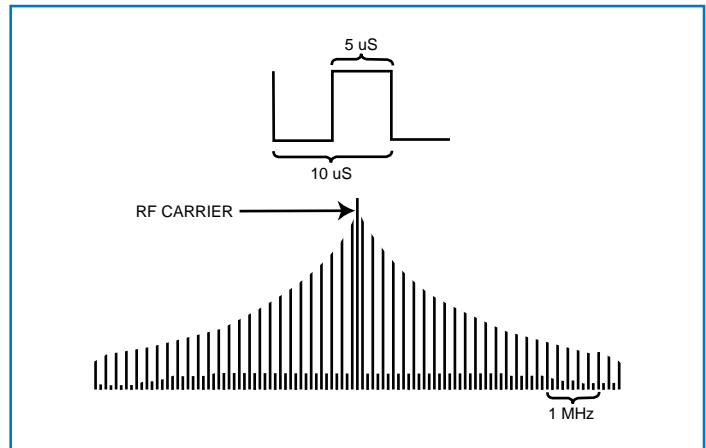

Figure 8. Modulated RF signal over frequency

Figure 9 shows a 100 kHz, 1  $\mu$ s pulse. Notice the lobes produced by the pulse. These are spaced at 1 MHz, that corresponds to the 1  $\mu$ s pulse width. Again, the combines are spaced at 100 kHz, but there are even harmonics in this signal. One other note here: the combines and lobes on a pulsed RF signal go out to approximately 100 MHz from the carrier. This bandwidth is determined by the rise time of the modulating signal. For a 10 ns rise time, they would go out at least 35 MHz from the carrier.

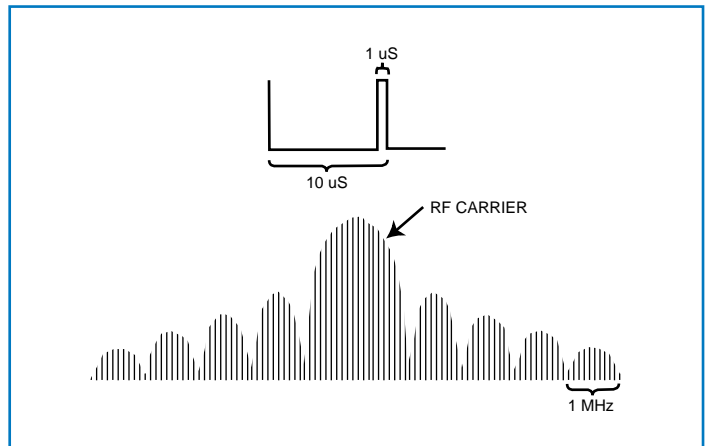

Figure 9. Unsuppressed even harmonics

The effects of the video feedthrough will not be evident in Figures 8 and 9. This is because the high frequency components of the video impulse are much lower in frequency than the RF carrier frequency. If we tune the spectrum analyzer down to 5 MHz, we can then see the video feedthrough as a combline similar to Figure 10. These should typically be on the order of  $-80$  dBm signal level and spaced at the frequency of the pulse video signal.

If we were to look at the output of the step-recovery diode used to drive the sampler in the YIG loop of the synthesizer, we would see much of the same signal. However, the comb lines would be spaced at the frequency of the Coarse Loop Oscillator and would go all the way past 40 GHz. This type of combline is produced by a very sharp impulse. The faster the rise-time, the higher in frequency the combines go to.

The combline caused by the video feedthrough will typically be worst case at the highest pulse repetition frequency. Since the frequency is higher, the harmonics will also include higher frequencies. This will not be evident when measuring video feedthrough with an oscilloscope. However, when measuring with a spectrum analyzer, the magnitude of the combline will increase as the pulse repetition frequency increases.

## Common Video Feedthrough Measurement

If the video feedthrough is very low in amplitude, most likely a filter must be inserted between the synthesizer and the spectrum analyzer to see it. The carrier frequency would then be tuned above the cut-off frequency of the filter to prevent overdriving the spectrum analyzer. This type of setup is shown in Figure 11.

This type of measurement of video feedthrough is more applicable when the synthesizer is used for receiver testing. If the low frequency video feedthrough is too high, the receiver will lock onto the video signal instead of the intended RF signal. A typical specification for this type of measurement is  $-60$  dBm. The MG3690A makes a typical  $-80$  to  $-85$  dBm.

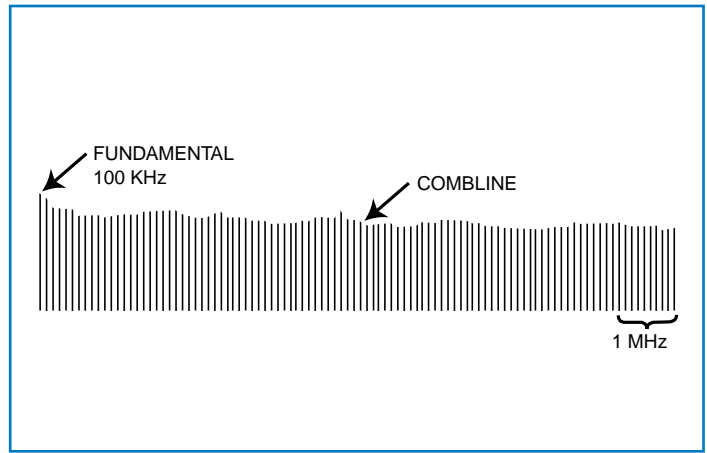

Figure 10. Video feedthrough as a combline

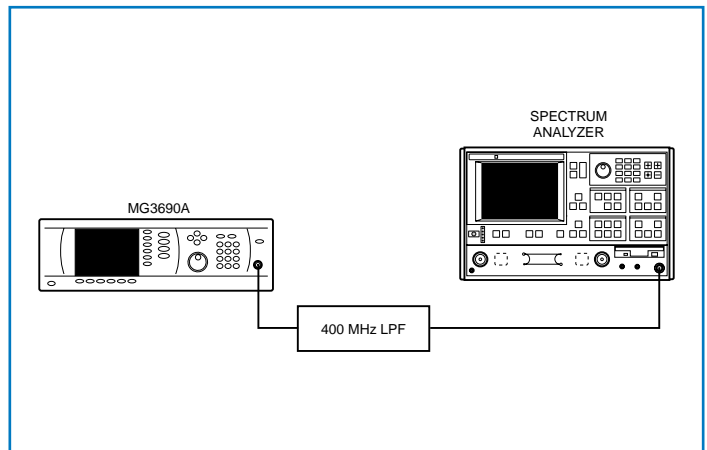

Figure 11. Low amplitude video feedthrough measurement

## Video Feedthrough Measurement in the Down-converter Band

Measurement of video feedthrough with an oscilloscope or spectrum analyzer can also cause misleading results when the RF carrier is in the down-converter band (0.01-2 GHz). The pulsing of the RF also pulses any spurious responses. The broadband noise floor of the down-converter changing between a RF ON and RF OFF condition can also cause misleading results. The best way to measure the true video feedthrough in the down-converter band is to disconnect the 2-8 GHz oscillator input to the control modulator. Any signal seen then will be true video feedthrough. Another point to remember is that the video feedthrough seen at control modulator output to the down-converter will be amplified 30 to 40 dB by the down-converter itself.

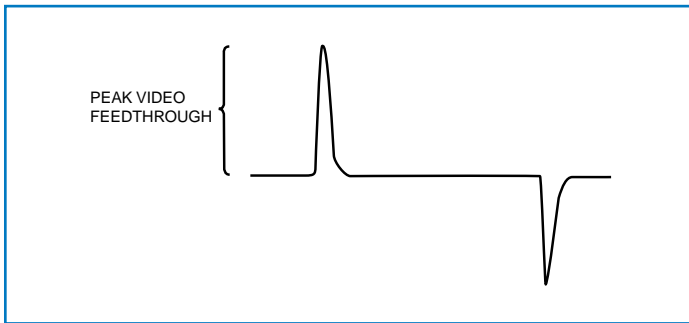

Figure 12. Output directly out of the synthesizer

If we look at the output of the synthesizer directly with an oscilloscope, we should see a signal similar to that shown in Figure 12. The peak value should meet the normal specification as shown in the synthesizer data sheet. Again, the low-pass filter is used to prevent the RF carrier from overdriving the oscilloscope. Even a 1 GHz signal applied directly to a 150 MHz oscilloscope can cause erroneous readings. The RF can be rectified by internal components in the input amplifier of the scope and show a signal that will mask the signal of interest.

Using the setup in Figure 11 with an oscilloscope in place of the spectrum analyzer and with the RF carrier frequency at 1 GHz, we see a signal as shown in Figure 12. However, by pressing the 20 MHz bandwidth limit on the oscilloscope, the amplitude decreases appreciably. This indicates spurious responses from the down-converter are masking the true video feedthrough. In this case, it would be better to disconnect the 2-8 GHz RF input to the control modulator. Then, pressing the 20 MHz bandwidth limit would only degrade the rise-time with very little effect, if any, on the peak amplitude of the impulse.

Another thing to keep in mind, especially in the down converter band, is that the video feedthrough does not change with the ALC power level control. It will change with each step of the step attenuator, if the synthesizer has one. If what appears to be video feedthrough changes with the level using only the ALC control range, it is not video feedthrough, it is the return overshoot on the RF.

In the microwave region above 2 GHz, the RF output of the synthesizer may be connected directly to the oscilloscope input. Video feedthrough may then be observed with pretty good accuracy and repeatability. The Anritsu MG3690A synthesizer has a typical performance of 500  $\mu$ V peak video feedthrough measured this way.

Using the TEK 494 or 492 spectrum analyzer with a RF carrier frequency above 2 GHz, one can get a dBm magnitude of the video in the frequency range of interest. Since these analyzers have a tracking filter above 1.8 GHz, the RF will not overdrive the input when looking at video feedthrough in the range of 0.01 to 1.8 GHz. Again, if you think you might be seeing some of the pulsed RF carrier, disconnect the oscillator input to the control modulator. The video feedthrough, if there is any, will still be present in the absence of the RF carrier.

## Video Feedthrough Measurement Using Waveguide

If you are measuring the output of a synthesizer with a crystal detector and oscilloscope as shown in Figure 13 and you suspect video feedthrough to be causing erroneous results, there is a very easy way to check it out. Use a pair of back-to-back waveguide-coax adapters between the RF output of the synthesizer and the crystal detector. Waveguide is an excellent high-pass filter and will block the video feedthrough. If the waveform changes shape with and without the high-pass filter, there is video feedthrough present.

Also, when measuring with an oscilloscope, the scope must be terminated in 50  $\Omega$ . If it is not, the video feedthrough could be as much as 100 times higher.

As we have discussed, there are two primary methods of measuring video feedthrough. Each has its advantages and disadvantages. The most general specification on synthesizers is a peak value as measured with an oscilloscope. This is a simple test, which does not involve lots of expensive test equipment. Although this type of test does not tell the whole story, it does give an indication of the amount of video feedthrough present. The test setup shown in Figure 11 is the most common way of measuring video feedthrough, even though it has some fallacies that are especially apparent when measuring the output of a down-converted frequency band.

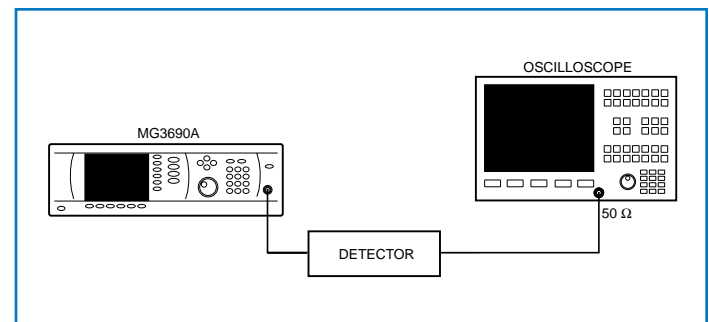

Figure 13. Measuring video feedthrough with waveguide

The more difficult measurement of video feedthrough in down-converted bands is not peculiar to any one manufacturer. It is peculiar to the down-conversion technique.

**Notes:**

**SALES CENTERS:**

United States (800) ANRITSU

Canada (800) ANRITSU

South America 55 (21) 286-9141

Europe 44 (0) 1582-433433

Japan 81 (46) 223-1111

Asia-Pacific (65) 6282-2400

Microwave Measurements Division

490 Jarvis Drive, Morgan Hill, CA 95037-2809

<http://www.us.anritsu.com>



**Anritsu**

Discover What's Possible®